

JAW BAR MACHINING
(TYP. BOTH ENDS)

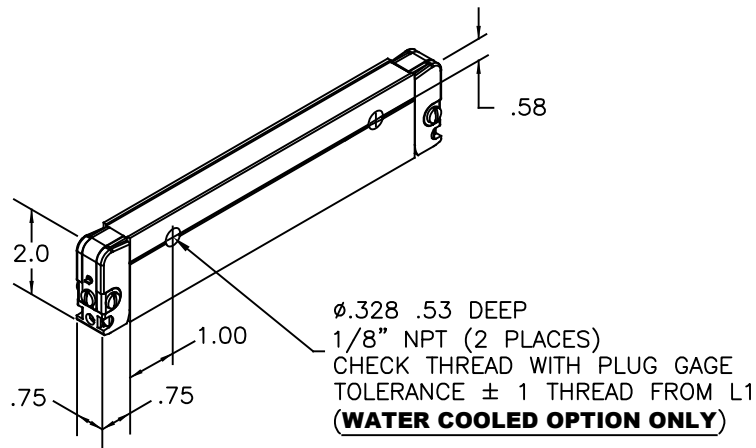

THIS DOCUMENT CONTAINS DESIGNS AND OTHER INFORMATION WHICH ARE THE CONFIDENTIAL PROPERTY OF TOSS MACHINE COMPONENTS. THE RECIPIENT ACKNOWLEDGES THAT THIS IS FURNISHED FOR ITS PRIVATE USE AND UPON THE EXPRESS AGREEMENT THAT IT WILL NOT REPRODUCE, COPY, EXHIBIT OR LEND IT IN WHOLE OR IN PART FOR ANY PURPOSE WHATSOEVER WITHOUT THE PRIOR WRITTEN CONSENT OF TOSS MACHINE COMPONENTS.

TOSS

MACHINE COMPONENTS INC.

539 S. MAIN ST., NAZARETH, PA 18064

DRAWN ML		TITLE JAW & STD JAW END KIT 3/4" X 2" HEAT SEAL BAR	
DATE 6/1/04		PART/DWG. NO. 440-STD	
CHK'D. -		DWG. SIZE A	REV. A
DATE _____		SCALE NONE	
ENG. APP'D. _____		SHEET 1 OF 1	
DATE _____			