

HCB-1

®

Operating Instructions

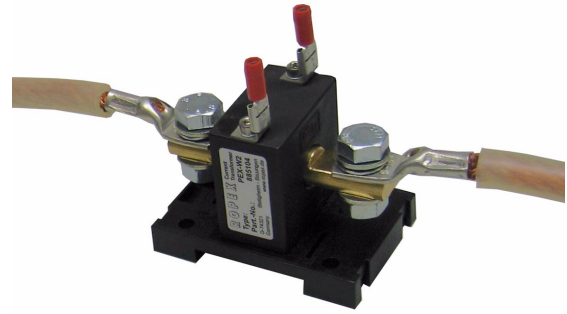

The current transformer (e.g. PEX-W2, MSW-1) supplied with RESISTRON/CIRUS temperature controllers is used to measure the current of the heatsealing band (secondary current of the impulse transformer) and is an integral part of the control system.

The transformer features a gland approximately 12mm in diameter for the high current wire. In applications with high secondary currents, the required cable cross-

section may be larger than the current transformer gland.

The HCB-1 high current busbar represents the ideal solution here. It is adapted to the size of the current transformer gland. M8 bolts for connecting large cable lug are provided at each end of the busbar.

⚠ The information provided in the ROPEX Application Report should be heeded when using the HCB-1 in order to avoid malfunctions.

Installation

The busbar must first of all be inserted through the gland and into the current transformer (Step 1). The high current wire is then fastened using the enclosed

fixing accessories (Step 2). The diagram below shows installation of the busbar on a PEX-W2 current transformer.

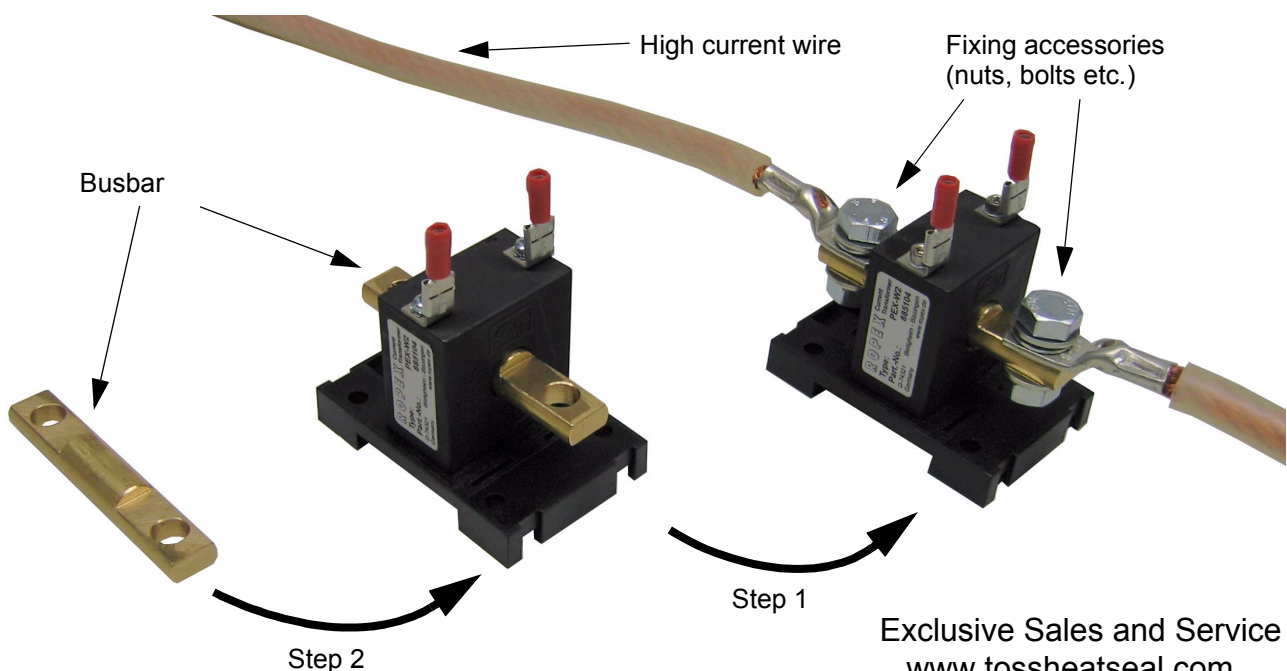

Exclusive Sales and Service :
www.tossheatseal.com

The high current wire must be connected as follows:

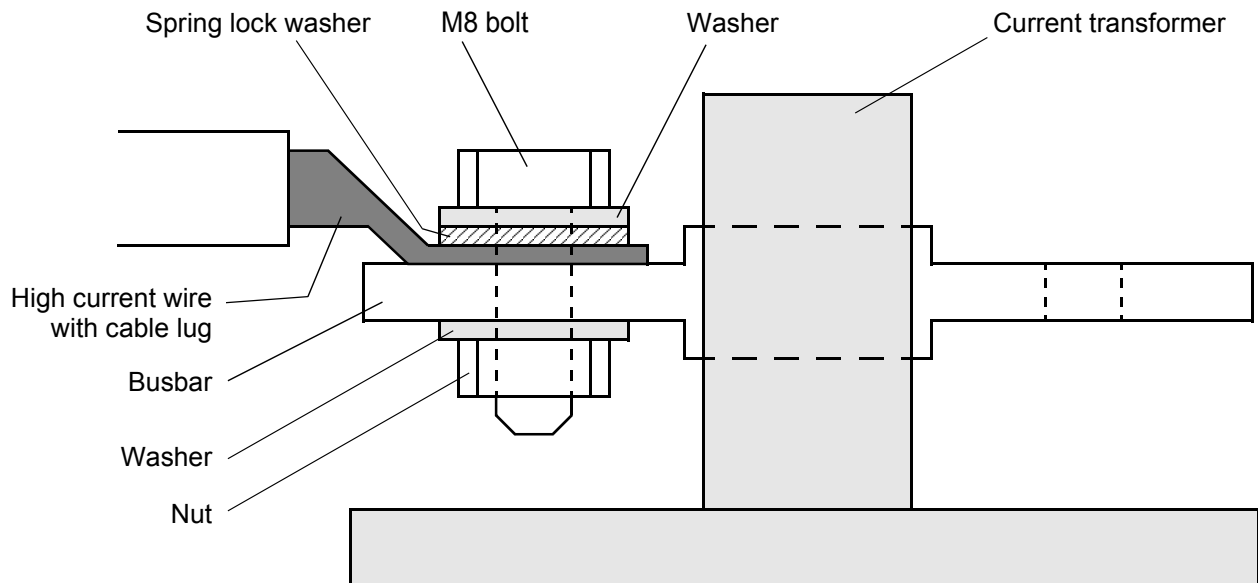

Scope of supply

The HCB-1 high current busbar is supplied with all the required fixing accessories. The scope of supply comprises:

- 1x busbar
- 2x bolt (M8x25)
- 2x spring lock washer (M8)
- 2x nut (M8)
- 4x washer (M8)



The HCB-1 high current busbar is only allowed to be installed using the enclosed fixing accessories in order to avoid malfunctions.

Maintenance

The HCB-1 high current busbar requires no special maintenance. Regular inspection and/or tightening of

the bolts is recommended. Dust deposits can be removed with dry compressed air.

How to order

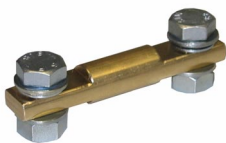

HCB-1 High current busbar for current transformer
Art. No. 885110